

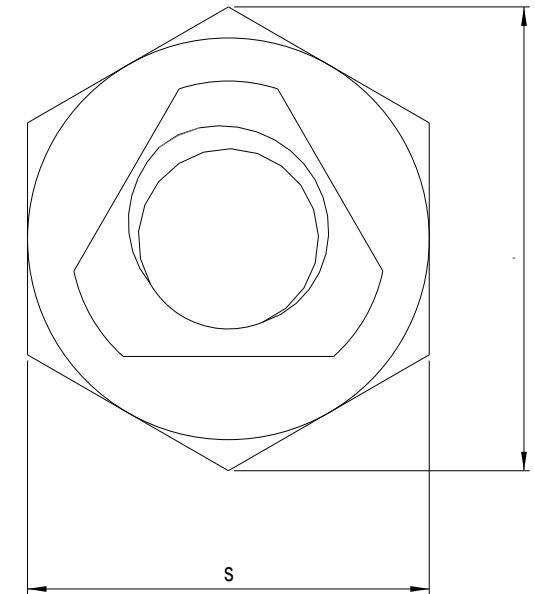

Further Information

Diameter (d)	Pitch	s	h
M3	0.50	5.50-5.32	3.70-3.40
M4	0.70	7.00-6.78	4.20-3.90
M5	0.80	8.00-7.78	5.10-4.80
M6	1.00	10.00-9.78	6.00-5.70
M7	1.00	11.00-10.73	7.00-6.50
M8	1.25	13.00-12.73	8.00-7.50
M10	1.50	17.00-16.73	10.00-9.00
M12	1.75	19.00-18.67	12.00-11.00
M14	2.00	22.00-21.67	14.00-12.00
M16	2.00	24.00-23.67	16.00-14.00
M18	2.50	27.00-26.16	18.00-16.00
M20	2.50	30.00-29.16	20.00-18.00
M22	2.50	32.00-31.00	22.00-20.00
M24	3.00	36.00-35.00	24.00-22.00

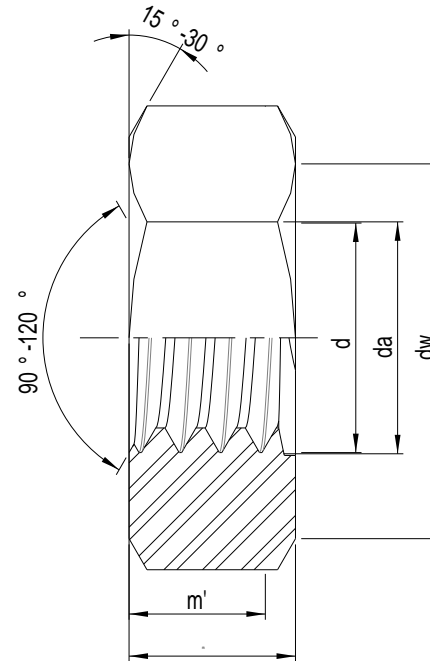

 PRECISION TECHNOLOGY SUPPLIES <small>Stainless Steel Industrial Fastenings & Precision Turned Parts</small>	Part No. A98018
www.pts-uk.com +44 (0)1342 410758	M18 ALLMETAL SELF LOCKING NUT Sim.980 A2 STAINLESS STEEL
Information in this drawing is provided for reference only	